

Submersible Grinder Pump Type ABS Piranha 08 - 125

SULZER

Submersible pumps for problem-free pumping of sewage containing faecal matter in pipe lines from 1¼" (DN 32).

Applications

Piranha submersible pumps have been designed for effective and economic dewatering using discharge lines of small diameter, in private, municipal and industrial areas.

- Sewage removal from living units and houses in remote settlements where the laying of a conventional sewer would be too expensive, where large ground undulations are present or where it is only possible to lay pipe lines of small diameter.
- Sewage removal from motorway resting sites, communal buildings and for renovation of buildings or areas of a city.
- For use in slaughter houses, food processing plants, paper factories, agriculture and similar areas.
- Piranha 08 and 09 are specially designed for private and domestic applications.
- Maximum allowable temperature of the medium is 40 °C, or short term to 60 °C (max. 5 minutes).

Construction

The water pressure-tight, encapsulated fully flood-proof motor and the pump section form a compact, robust, unit construction.

Bearings

The stainless steel motor shaft is supported in lubricated-for-life ball bearings.

Shaft sealing

Piranha 08 - S30: Between motor and hydraulic section by means of a high quality sealing unit using a silicon carbide mechanical seal. Seal at motor side is by oil lubricated lip seal.

Piranha PE25/2C - 125/2E: Double mechanical seals, SiC-SiC at the hydraulic side, SiC-C at the motor.

All seals are independent of direction of rotation and resistant to temperature shock.

Discharge

Piranha 08 and 09: DN 32 flange with G 1¼" internal thread.

Piranha S10 - PE45/2C: DN 32 flange (G 1¼" threaded adaptor available as accessory).

Piranha PE80/2E - PE125/2E: DN 50 with DIN-flange.

Shredding system

Spiral bottom plate and stationary cutter ring combined with a shredding rotor located before the impeller, for optimum blockage-free running.

Temperature monitoring

Thermal sensors in the stator to switch off the pump in the case of overheating and switch on automatically after cooling down. Temperature and leakage relays are required (see accessories table).

Seal monitoring

DI system consisting of a sensor in the motor and oil chambers which signals an inspection alert if there is leakage at the shaft seals. Not available for Piranha 08 and 09. Temperature and leakage relays are required (see accessories table).



Features

- Unique Piranha shredding system capable of shredding items such as cloths and plastic bags.
- For the pumping of wastewater containing sewage, offal, organic and industrial effluent.
- Piranha 08 and 09 fitted with MF modular motor; Piranha-S with AS, Piranha PE with XFP Premium Efficiency IE3.
- Small discharge lines from 1¼" (DN 32).
- Installations are possible where large ground undulations are present.
- Standard and Ex-versions (see motor data below).
- Piranha 08 and 09 have capacitor in upper lid and do not require a control box.
- Low installation costs due to small diameter discharge pipework.

Motor

Three-phase 460 V or single-phase 230 V, 60 Hz, 2-pole (3400 r/min) or 4-pole (1750 r/min).

Cooled by amply dimensioned cooling areas.

Piranha 08 & 09: insulation class F, protection type IP 68, non-Ex only.

Piranha S10 - S30: insulation class F, protection type IP 68, Ex and non-Ex.

Piranha PE25/2C - PE125/2E: Premium Efficiency IE3 with NEMA Class A temperature rise, insulation class H, protection type IP 68, Ex only.

Explosive-proof versions are in accordance with international standard ATEX II 2G Ex h db IIB T4 Gb.

Types of operation and frequency of starting: Piranha-S has been designed for intermittent use only (S3, 25%) when dry-installed, and continuous use (S1) when submerged.

Pumps of the Piranha-PE series have been designed for continuous operation S1 when either submerged or dry-installed

Technical data

Piranha W = 1-phase D = 3-phase	Discharge		Motor power ** (kW)		Rated current (A)	Rated voltage (V)	Speed (r/min)	Cable size Std & Ex	Weight *** (kg)
	Flange DN	Internal thread *	P ₁	P ₂					
08/2W	32	G 1¼"	2.15	1.50	9.39	230 1~	3400	SJTOW-A 16/3	18
08/2D	32	G 1¼"	1.85	1.50	2.87	460 3~	3400	STOW-A 16/4	18
09/2W	32	G 1¼"	2.83	2.25	13.50	230 1~	3400	SJTOW-A 16/3	23
09/2D	32	G 1¼"	2.53	2.00	3.98	460 3~	3400	STOW-A 16/4	23
S10/4W†	32	G 1¼"	1.48	1.00	6.50	230 1~	1750	SOW-A 14/7	36
S10/4D	32	G 1"	1.33	1.00	2.60	460 3~	1750	SOW-A 14/7	36
S20/2W†	32	G 1¼"	2.45	1.80	11.50	230 1~	3400	SOW-A 14/7	36
S20/2D	32	G 1¼"	2.42	1.80	3.61	460 3~	3400	SOW-A 14/7	36
S26/2W†	32	G 1¼"	3.13	2.60	13.70	230 1~	3400	SOW-A 14/7	41
S30/2D	32	G 1¼"	3.87	3.00	5.50	460 3~	3400	SOW-A 14/7	57
PE25/2W-C	32	G 1¼"	3.74	2.50	16.60	230 1~	3400	SOOW 12/7	86
PE28/2D-C	32	G 1¼"	3.21	2.80	4.72	460 3~	3400	SOOW 14/7	84
PE35/2W-C	32	G 1¼"	4.53	4.00	20.03	230 1~	3400	SOOW 10/7	88
PE35/2D-C	32	G 1¼"	4.48	4.00	6.48	460 3~	3400	SOOW 14/7	84
PE45/2W-C	32	G 1¼"	5.11	4.50	22.40	230 1~	3400	AWM 8/4+16/3	91
PE45/2D-C	32	G 1¼"	5.61	5.00	7.99	460 3~	3400	"SOOW 12/7	89
PE80/2D-E	50 DIN	-	8.87	8.00	13.30	460 3~	3400	"SOOW 12/7	133
PE100/2D-E	50 DIN	-	10.80	10.00	17.30	460 3~	3400	"SOOW 10/7	164
PE110/2D-E	50 DIN	-	12.00	11.00	18.60	460 3~	3400	"SOOW 10/7	164
PE125/2D-E	50 DIN	-	13.70	12.50	21.30	460 3~	3400	AWM 8/4+16/3	164

* Piranha 08 and 09 flange has internal thread. Piranha S10/4 - PE45/2D-C has threaded flange adaptor as optional accessory.

** P₁ = Power at mains; P₂ = Power at motor shaft.

*** Weight with 15 m cable

† Start and Run capacitor to the following specification required in control panel:

Start: 161-193µF for S10/4W & S20/2W, 200µF for S26/2W.

Run: 30µF for S10/4W, 20µF for S20/2W, 50µF for S26/2W.

The recommended start time for the motors is two seconds.

Performance curves

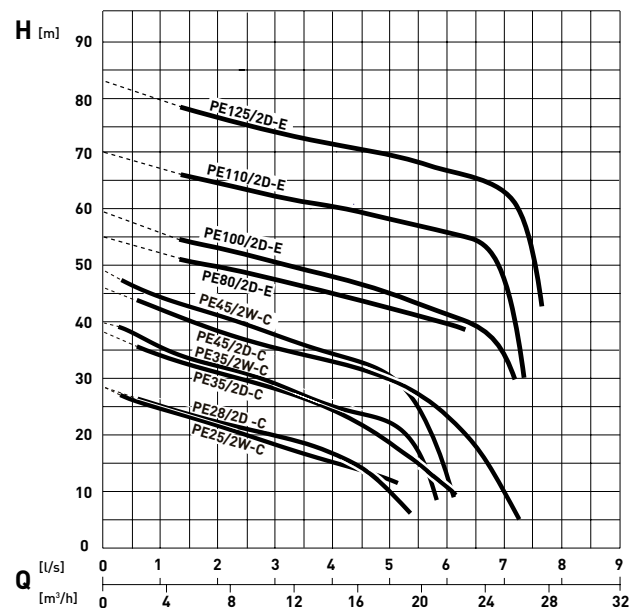
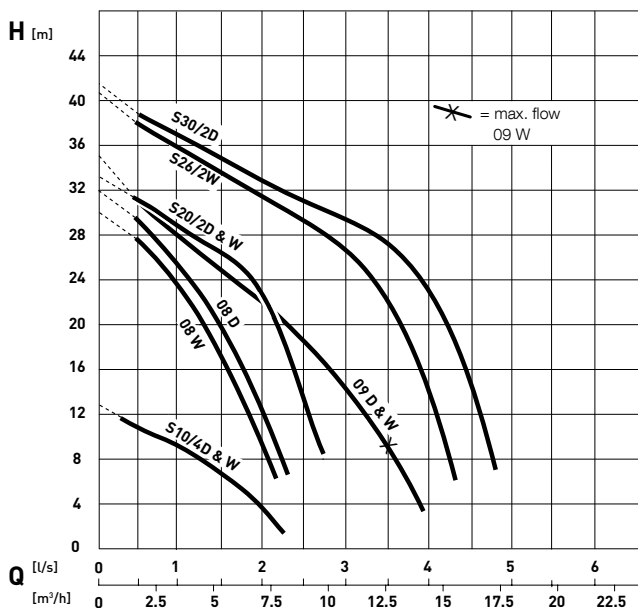

H = Total Head; Q = Discharge Volume.

Curves to ISO 9906

N.B. please use the ABSEL program to validate pump selection.

Dimensions (mm)

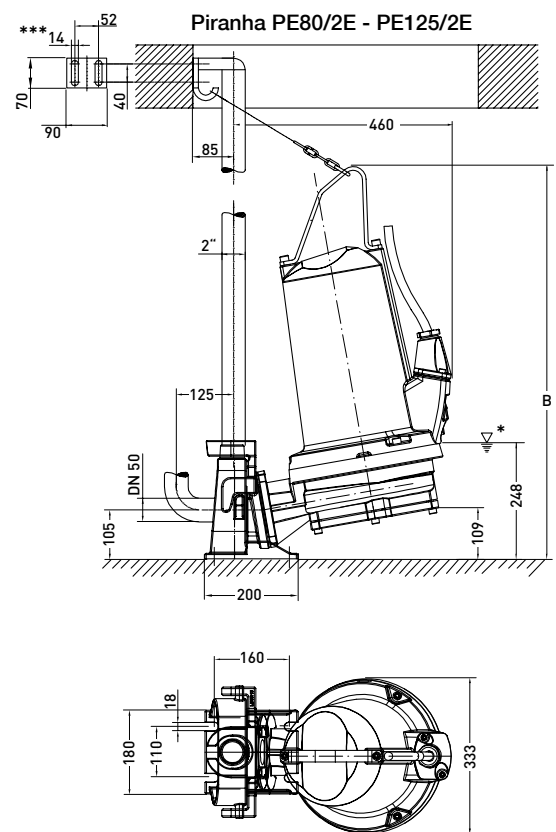
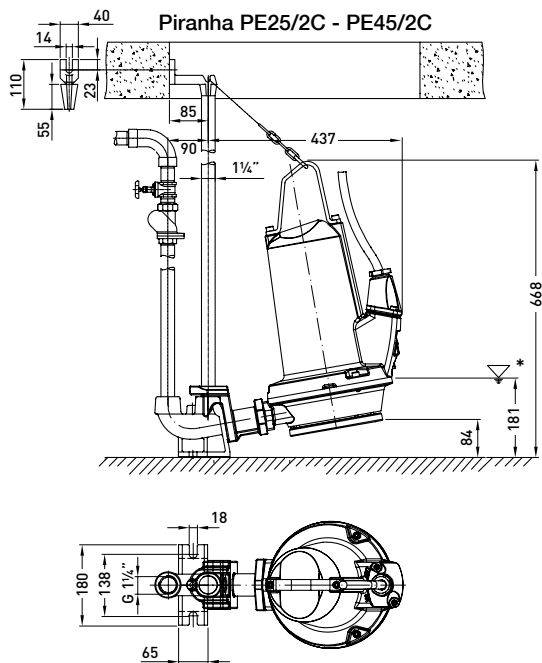
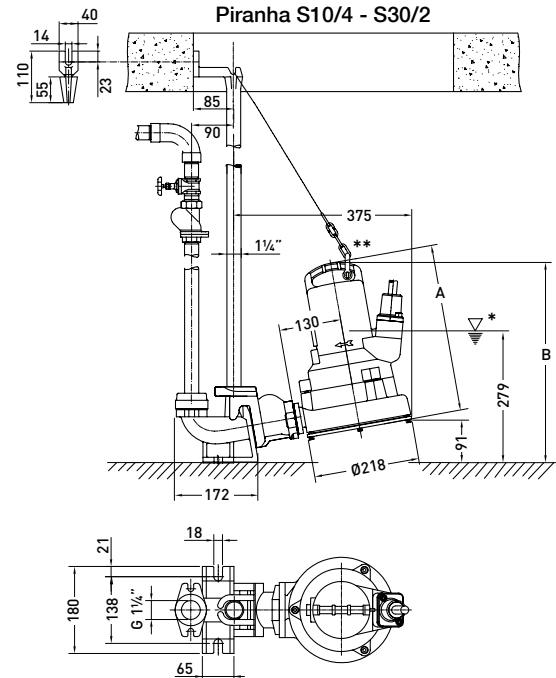
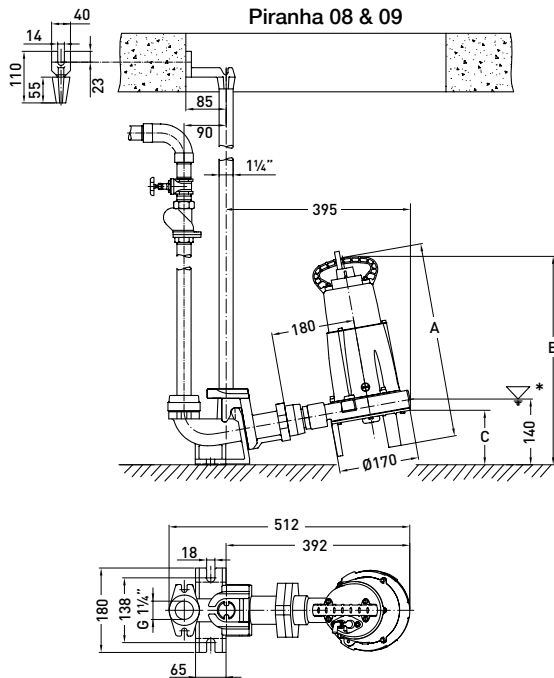

Piranha 08 - PE125/2E: Minimum sump opening \varnothing 625 mm.
Pedestal base secured using M10 masonry anchor bolts, drill hole size 14 mm.
* Lowest switch-off point for automatic operation.

Piranha S10/4 - S30/2: ** To allow the pump to be lowered and fixed correctly to the pedestal, the shackle must be fixed to the handle at the point furthest from the guide rail.

Piranha PE80/2E - PE125/2E: Discharge line connection with threaded flange DN 50/2" PN16.
Discharge elbow supplied by customer.
*** Hexagon head wood screw 10 x 70 DIN 571 and dowel size 12.

Piranha	A	B	C
08	420	445	117
09	445	470	108
S10/4 & S20/2	347	414	368
S26/2 & S30/2	360	427	374
PE80/2E	-	774	-
PE110/2E - PE125/2E	-	844	-

Materials

Description	Material
Upper lid *	Stainless steel 1.4301 (AISI 304)
Motor housing	Cast iron EN-GJL-250
Rotor shaft	Stainless steel 1.4021 (AISI 420)
Volute	Cast iron EN-GJL-250
Impeller **	Cast iron EN-GJL-250
Fasteners	Stainless steel 1.4401 (AISI 316)

* Piranha 08 and 09. ** Polyamide for Piranha 08

Accessories

	Description	Size	Part no.	Piranha
Fixed installation with pedestal	Pedestal (cast iron EN-GJL-250) 90° cast bend	G 1¼"	62325007	08 & 09
		G 1¼"	62320674	S10/4 - S30/2
		G 1¼"	62320676	PE25/2C - 45/2C
	90° cast bend with built-in non-return valve without bend	G 1¼"	62320536	S10/4 - S30/2
		G 1¼"	62320538	PE25/2C - 45/2C
		DN 50/G2"	62320660	PE80/2E - 125/2E
	Threaded Adaptor hexagon double nipple	G 1¼"	13770011	08 & 09
	Guide Rail (galvanized steel)	1¼" x 1 m	31380007	08 - PE125/2E
		1¼" x 2 m	31380008	
		1¼" x 3 m	31380009	
1¼" x 4 m		31380010		
1¼" x 5 m		31380011		
Chain Kit (stainless steel) including shackle	3 m	310101236013	08 - PE125/2E	
	4 m	310101236014		
	6 m	310101236016		
	7 m	310101236017		
Transportable applications	Threaded Flange Kit (EN-GJL-250) including discharge piece, gasket and bolts	G 1¼"	61180512	S10/4 - PE45/2C
	Ground Support Stand (St. 37) with fixing bolts		61900013 61900007	S10/4 - S30/2 PE25/2C - 125/2E
	Fixed Coupling (brass) GEKA with external thread	G 1¼"	15020003	S10/4 - PE45/2C
Horizontal (tank connection)	Pump with built-in flange on suction side	DN 150/PN 16 to DIN 2633	On request	S10/4 - PE125/2E
	Head Support (EN-GJL-250) with vibration damping		62665103	S10/4 - S30/2
General	Non-return Valve (EN-GJL-250) ball valve with internal thread	G1¼"	61400525	08 - PE125/2E
		G1½"	61400526	
		G2"	61400527	
	Shut-off Valve (brass) with internal thread	G1¼"	14040005	08 - PE125/2E
		G1½"	14040006	
		G2"	14040007	
	Leakage Relay Type ABS CA 461	110 - 230 VAC	16907010	08 - PE125/2E
18 - 36 VDC, SELV		16907011	08 - PE125/2E	
Temperature and Leakage Relay Type ABS CA 462	110 - 230 VAC	16907006	08 - PE125/2E	
	18 - 36 VDC, SELV	16907007	08 - PE125/2E	